

S.A. VIDEO SYSTEM KIT

Visiopro monitor + VP2



Equipments
for automatic
welding
applications.

TECHNICAL CHARACTERISTICS

- 1** Video kit to follow Submerged Arc welding joints.
- 2** A spotlight provided with the kit gives illumination over viewed area, indispensable for welding inside a tube for example.
- 3** The video kit is associated with a colour LCD industrial screen 15 inches, high definition with a protection box.

Cat. n° for complete S.A. VIDEO KIT: : ~~W 000 6 076~~



Camera for video kit



15 inches LCD screen with protection

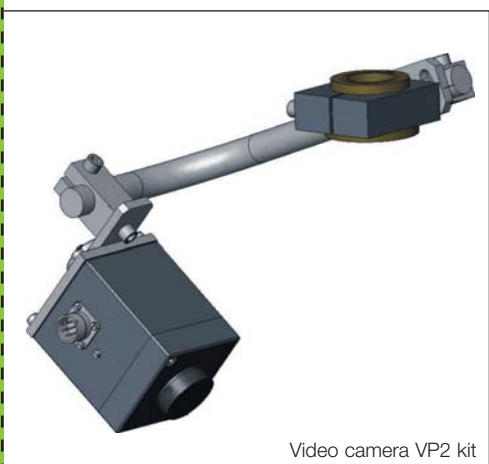

Video camera VP2 kit

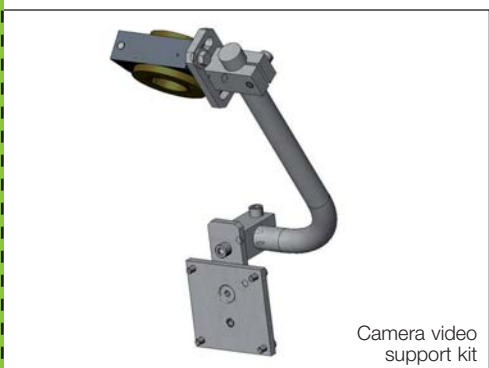

Camera video support kit

Video system kit

Cat. n°	COMPLETE KIT SCREEN + CAMERA
W 000 315 880	Video kit S.A. LCD
Cat. n°	SCREEN VIDEO KIT
W 000 315 881	15 inches LCD screen with protection
Cat. n°	CAMERA FOR VIDEO KIT
W 000 315 882	VISIOPRO VP2 with S.A. camera

Spare parts

Cat. n°	VIDEO CAMERA VP2 (W 000 236 075)
W 000 268 013	Video camera VP2 kit
W 000 268 012	Harness 22 m length for camera
W 000 268 015	Spotlight
W 000 268 014	Harness 22 m length for spotlight
W 000 268 011	Isolating ring
W 000 141 387	1 bulb for spotlight 24V 20W
Cat. n°	15 INCHES LCD SCREEN (W 000 236 076)
W 000 268 019	15 inches screen VMC 15 LCD P
W 000 268 018	Screen protection
W 000 268 017	Harness 22 m length for video screen
W 000 268 016	Connection kit

