

Positioning equipment

Since control over the welding process is the key to any system's performance, Air Liquide Welding offer procedural support in addition to their range of positioning equipment.

Air Liquide Welding's range of positioning equipment includes:

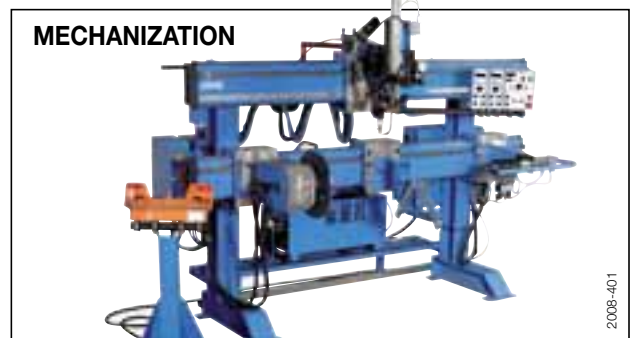
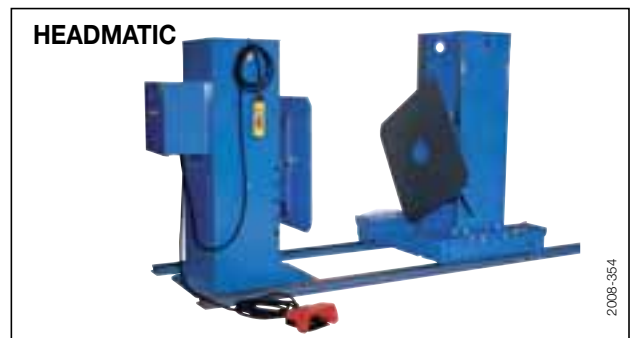
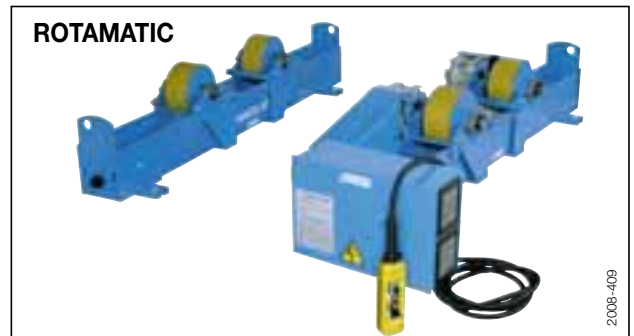
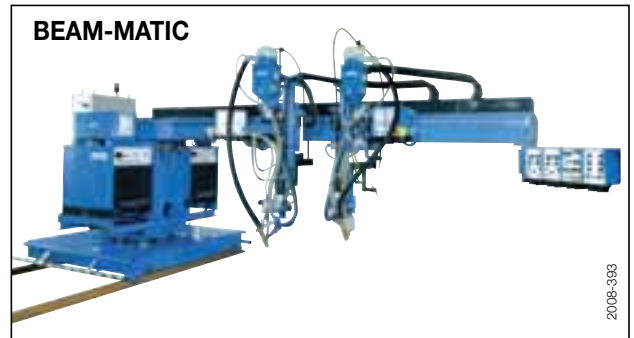
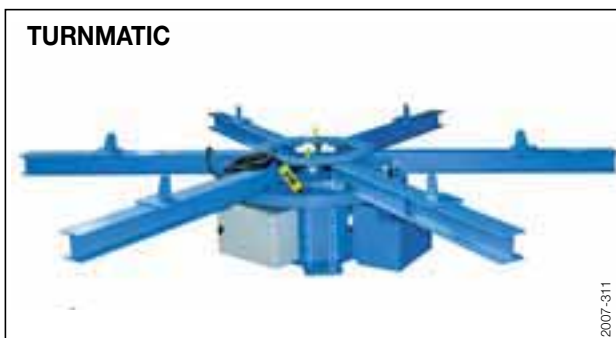
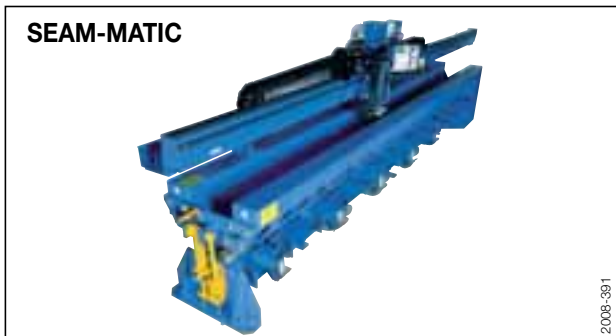

Here, just a few of the most usual configurations available to suit your working and production areas. We are always happy to develop a new solution to meet your requirements.

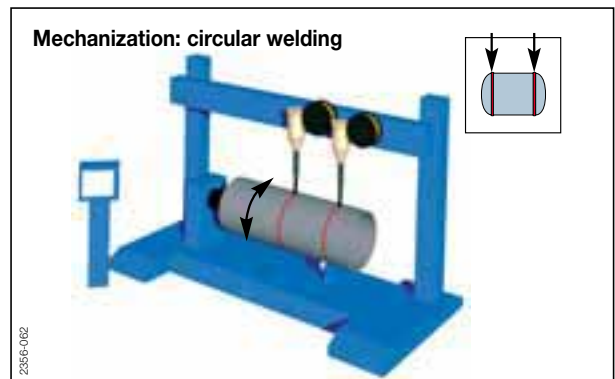
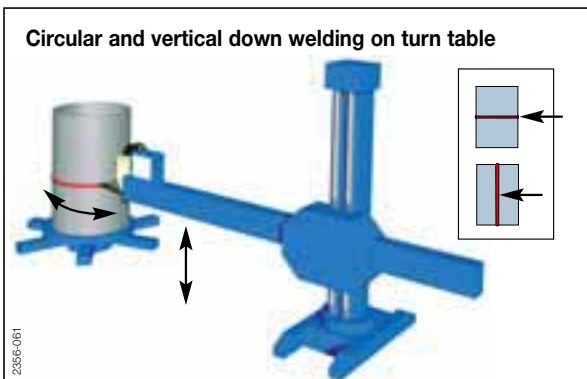
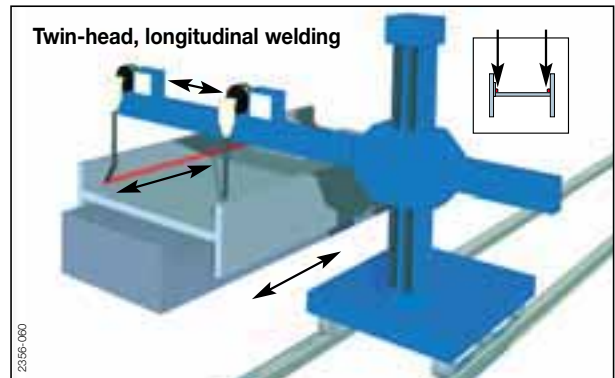
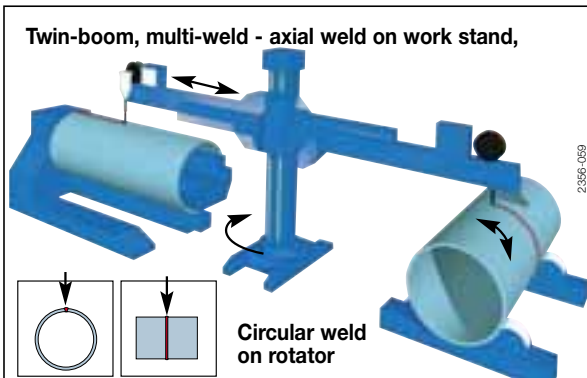
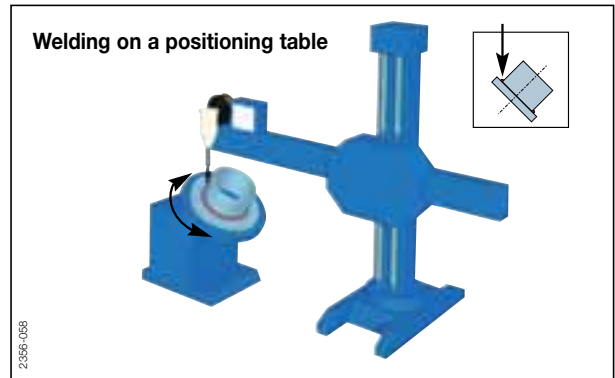
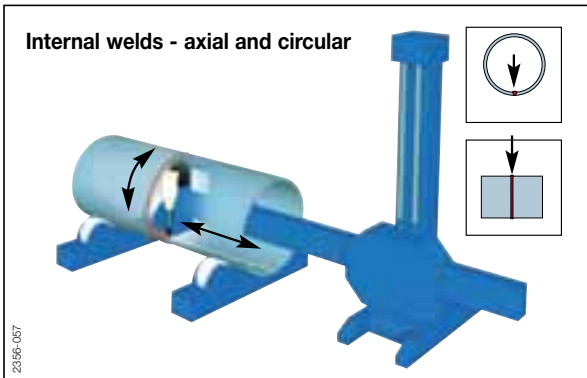
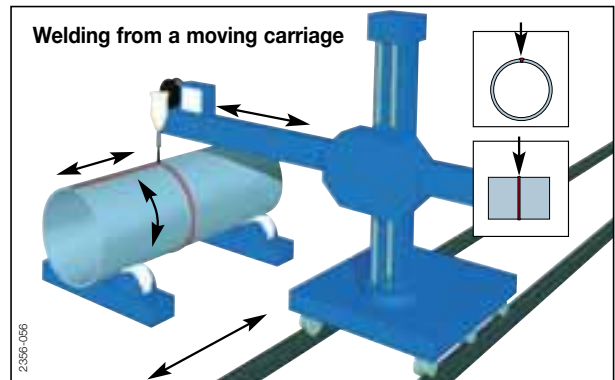
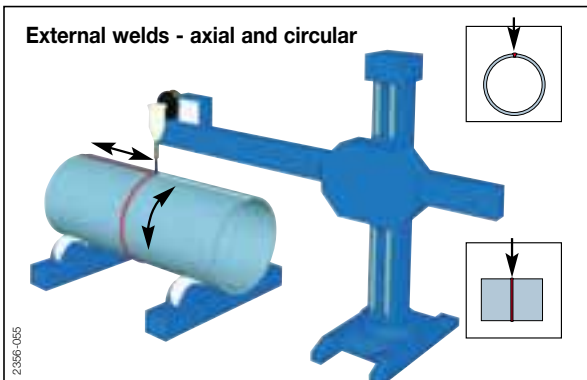

Column & Booms: CB-MATIC

Air Liquide Welding column and booms are the professional answer to your needs. Ideal for pressure vessels manufactured from stainless steel, mild steel and light alloy, they maximise your benefit from automatic MIG, submerged arc, TIG, plasma and plasma + TIG welding processes. Developed by the welding specialists, Air Liquide Welding's world-reknoned technology is at your service.

Standard Range:

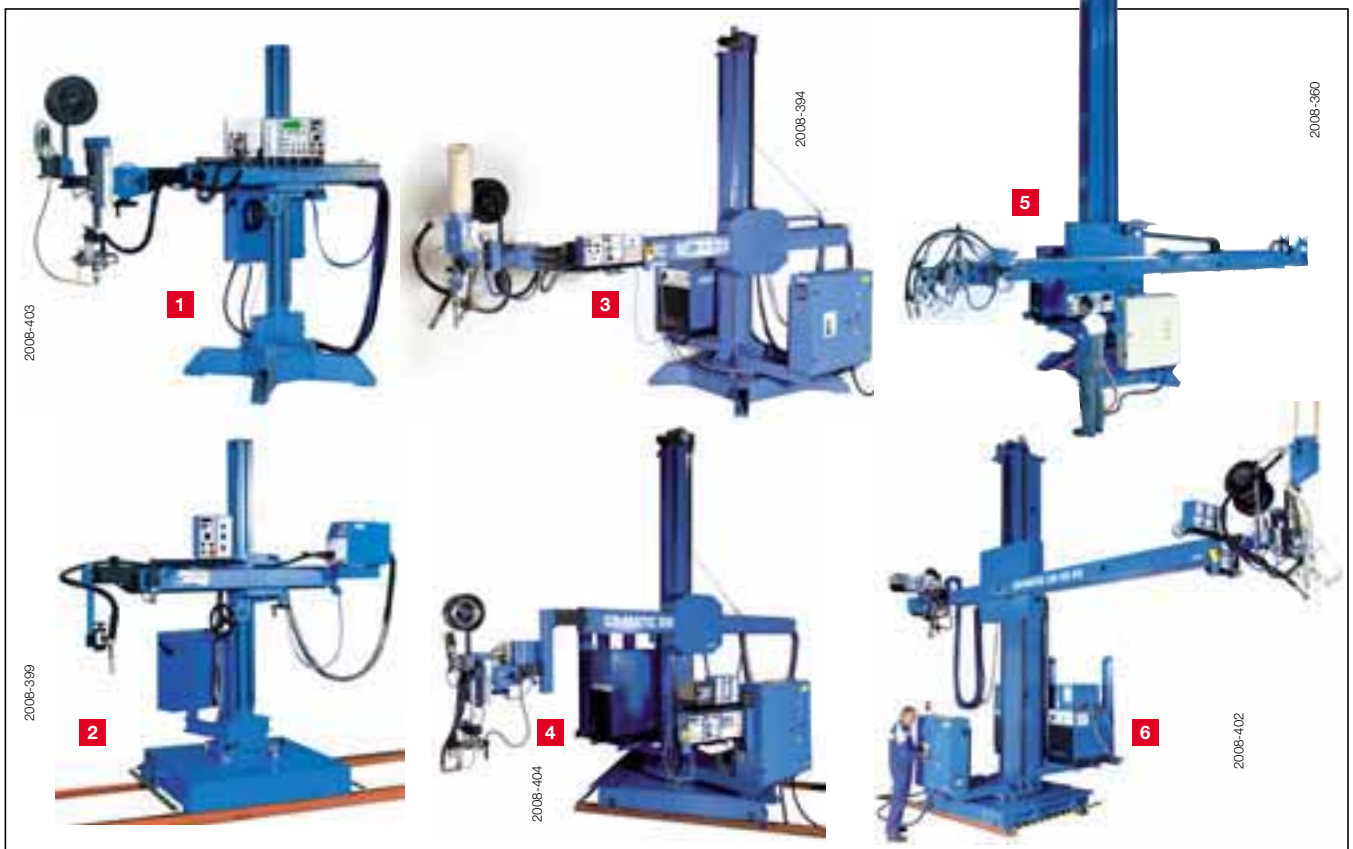

In standard, all the column and boom are equipped with:

- control panels on both main cabinet and end of the arm,
- CE electrical cabinet,
- full stop on motorized carriage.

Designation	Manual range		Medium range						
	1 LF 15 x 10	2 LM 15 x 10	3 SF 25 x 23	3 SF 32 x 33	42 x 43	4 SM 25 x 23	4 SM 32 x 33	42 x 43	
Cat. no.	W 000 315 225	W 000 315 422	W 000 315 227	W 000 315 229	W 000 315 231	W 000 315 226	W 000 315 228	W 000 315 230	
Displacement									
Vertical travel	mm	1 500	1 500	2 500	3 200	4 200	2 500	3 200	4 200
Arm speed	cm/min	manual	manual	10 to 100	10 to 100	10 to 100	10 to 100	10 to 100	10 to 100
Horizontal travel	mm	1 000	1 000	2 300	3 300	4 300	2 300	3 300	4 300
Arm speed	cm/min	manual	manual	12 to 200	12 to 200	12 to 200	12 to 200	12 to 200	
Carriage speed	cm/min	-	57 to 570	-	-	-	10 to 480	10 to 480	10 to 480
Height	mm	2 595	2 660	4 240	4 940	5 940	4 250	4 950	5 950
Maximum load at end of arm	kg	70	70	200	175	150	200	175	150

SF = Boom on fixed base with circular rotary shaft
SM = Boom on powered carriage with circular rotary shaft

LF = Boom on fixed base with square rotary shaft
LM = Boom on powered carriage with square rotary shaft

Please contact our agents for any sizes or specific requirements not shown in the table.

Available standard options:

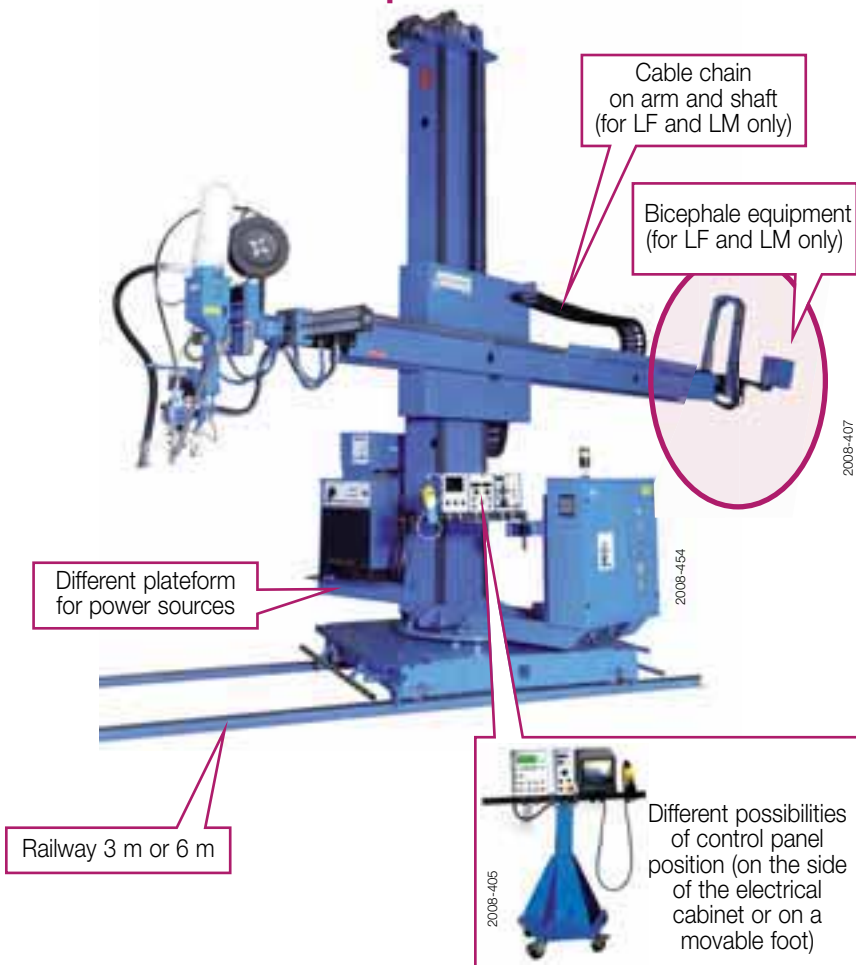

Customized CB-MATIC:

COLUMN AND BOOM BIG SIZE.
Specific size: **Consult us**



PERIPHERICS INTEGRATION:
Seamer, positioning equipment...
Consult us



SEAT OPERATOR WITH CE CERTIFICATION:
Consult us

Heavy range

5 LF					6 LM				
25 x 23	32 x 33	42 x 43	52 x 43	62 x 43	25 x 23	32 x 33	42 x 43	52 x 43	62 x 43
W 000 315 244	W 000 315 245	W 000 315 246	W 000 315 247	W 000 315 248	W 000 315 239	W 000 315 240	W 000 315 241	W 000 315 242	W 000 315 243
2 200	3 200	4 200	5 200	6 200	2 500	3 200	4 200	5 200	6 200
27 to 110	2 to 110	27 to 110	27 to 110	27 to 110	27 to 110	27 to 110	27 to 110	27 to 110	27 to 110
2 300	3 300	4 300	4 300	4 300	2 300	3 300	4 300	4 300	4 300
5 to 480	5 to 480	5 to 480	5 to 480	5 to 480	5 to 480	5 to 480	5 to 480	5 to 480	5 to 480
-	-	-	-	-	5 to 480	5 to 480	5 to 480	5 to 480	5 to 480
4 850	5 550	6 550	7 550	8 550	4 850	5 550	6 550	7 550	8 550
520	460	400	400	400	520	460	400	400	400

Seamers: SEAM-MATIC



Air Liquide Welding offers a range of seamers specifically designed for horizontal welding, supporting flat or cylindrical (round or square section) workpieces with a wide range of dimensions.

5 types of seamers: PL: flat sheet, FIN: small thickness, EX: external welding, IT: internal welding and EXIT: external/internal welding



In standard solution:

CABLE CHAIN

In standard configuration :

- FIN : cable chain normal
- IT and EXIT: cable chain head to foot
- PL and EX : cable carrying garland

Possibility to have cable chain normal or head to foot in option (requested for plasma or TIG)



CONTROL PANEL

For all seamers, possibility to have control panel on the welding head, or on a movable foot.



Customized solution:

OPERATOR PLATFORM

For EX seamer: operator platform
Consult us

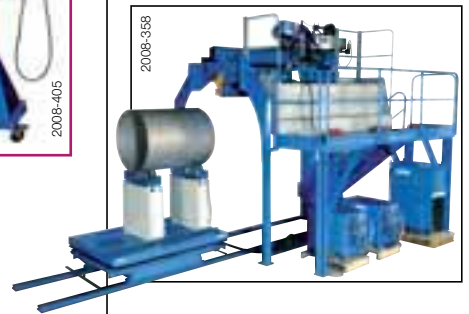

SHEET SUPPORT

For IT seamer: sheet support for in and out of the seamer
Consult us

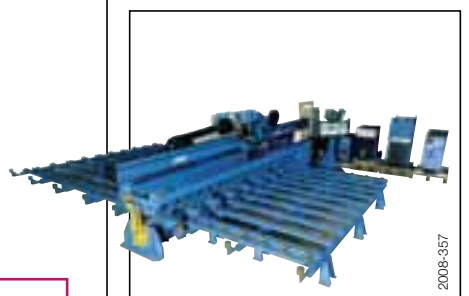

OPEN DEVICE

In standard, the open device is manual. For the EX seamer, there is the possibility to have a pneumatic open device.

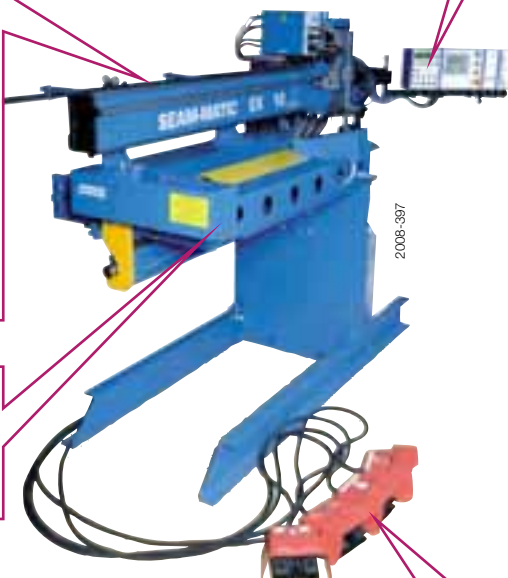

CONTROL PEDAL

Operating pedals used to open or close the clamps.

Welding direction 1 →

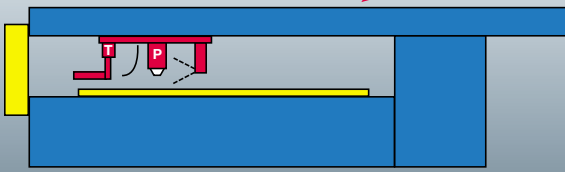

Weldable length rules:

- For mono-cathode = no difference
- For bi-cathode plasma+TIG = only for welding direction 1
 - Inter and Exinter: up to size 52 included = - 250 mm
 - over size 52 = - 200 mm
 - No difference if added video or trailer bar
- consult us for:
 - For the other welding direction
 - Plasma+TIG in Exter seamer

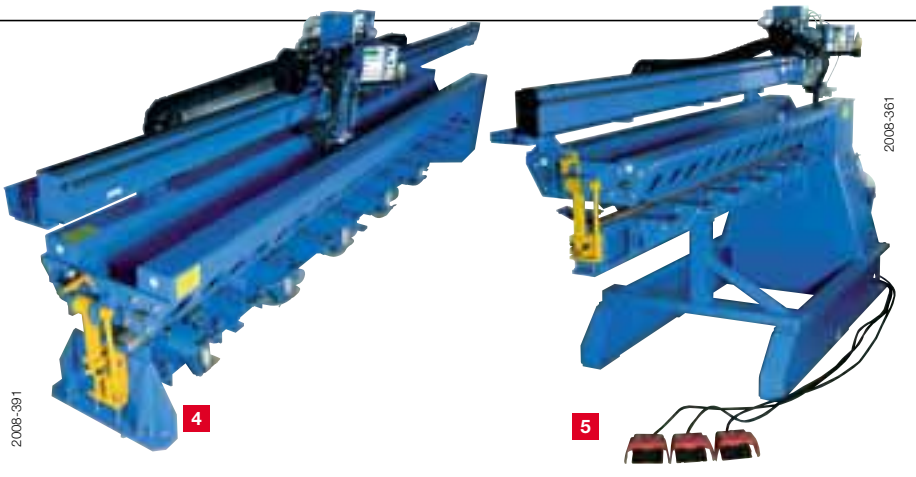

Please contact our agents for any sizes or specific requirements not shown in the table.

Plan (PL)



Finexter (FIN)



Exter (EX)

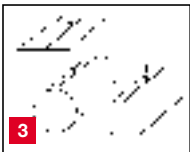

Inter (IT)



Exinter (EXIT)



Designation	Cat. no.	Workpiece specifications						
		Maximum weldable length (included run on/off plates) (mm)	External welding (mm)*		Internal welding (mm)*	Thickness (mm)		
			Ø mini	Ø maxi	Ø mini	without tacking	with tacking	
PL 22	W 000 315 132	2 250	-	-	-	1 to 5	1 to 8	
PL 32	W 000 315 133	3 250	-	-	-	1 to 5	1 to 8	
PL 42	W 000 315 134	4 250	-	-	-	1 to 5	1 to 8	
PL 52	W 000 315 135	5 250	-	-	-	1 to 5	1 to 8	
PL 62	W 000 315 136	6 250	-	-	-	1 to 5	1 to 8	
FIN 10 v 07	W 000 271 848	1 050	80	700	-	0,6 to 3	0,6 to 3	
EX 06 V 10	W 000 315 144	650	180	1 000	-	0.8 to 4	0.8 to 8	
EX 12 V 10	W 000 315 155	1 250	210	1 000	-	0.8 to 5	0.8 to 8	
EX 17 V 10	W 000 315 165	1 750	220	1 000	-	0.8 to 5	0.8 to 8	
EX 22 V 10	W 000 315 176	2 250	270	1 000	-	1 to 5	1 to 8	
EX 22 V 15	W 000 315 205	2 250	270	1 500	-	1 to 5	1 to 8	
EX 32 V 10	W 000 315 188	3 250	320	1 000	-	1 to 5	1 to 8	
EX 32 V 15	W 000 315 211	3 250	320	1 500	-	1 to 5	1 to 8	
EX 42 V 10	W 000 315 199	4 250	460	1 000	-	1 to 5	1 to 8	
EX 42 V 15	W 000 315 212	4 250	460	1 500	-	1 to 5	1 to 8	
IT 22	W 000 315 213	2 250	-	-	1450	1 to 5	1 to 10	
IT 32	W 000 315 214	3 250	-	-	1450	1 to 5	1 to 10	
IT 42	W 000 315 215	4 250	-	-	1450	1 to 5	1 to 10	
IT 52	W 000 315 216	5 250	-	-	1500	1 to 5	1 to 10	
IT 62	W 000 315 217	6 250	-	-	1500	1 to 5	1 to 10	
IT 72	W 000 315 218	7 250	-	-	1600	1 to 5	1 to 10	
EXIT 32	W 000 315 219	3 250	380	1450	1450	1 to 5	1 to 10	
EXIT 42	W 000 315 220	4 250	480	1450	1450	1 to 5	1 to 10	
EXIT 52	W 000 315 221	5 250	580	1500	1500	1 to 5	1 to 10	
EXIT 62	W 000 315 222	6 250	600	1500	1500	1 to 5	1 to 10	

* For other size: **consult us**

Beam welding machine: BEAM-MATIC

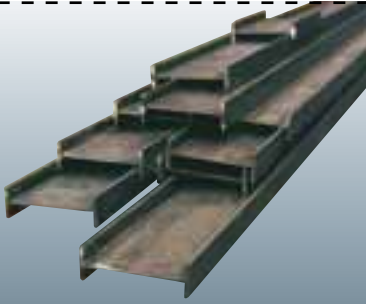

The automation of long workpieces welding (beams, wagons, box section constructions) requires sophisticated machines which move on rails.

The BEAM-MATIC system is used to weld castellated welded beams of constant or varying cross-section in widths between 220 and 2 000 mm. For other dimensions, consult us.

BEAM-MATIC

2 types of Beam-matic are available:

- PRS cantilever: **CT**
- PRS on base column and boom: **LM**

The beam-matic allows to weld in MIG or SAW (single or twin wire). In standard, there is push flux and flux recovery. Possibility to use wire spool or wire drum on the 2 Beam-matics.

The torch level is fix on the beam-matic CT and it's possible to lift the torch level on the Beam-matic LM.

BEAM-MATIC CT

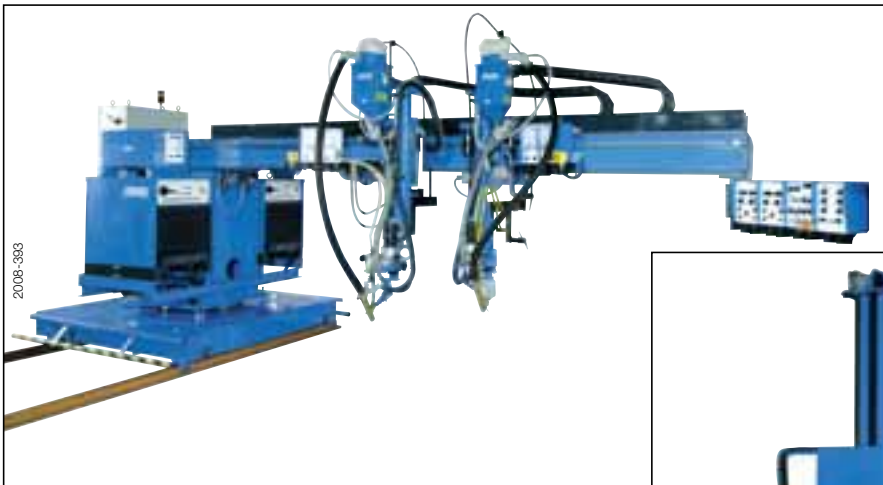

BEAM-MATIC LM

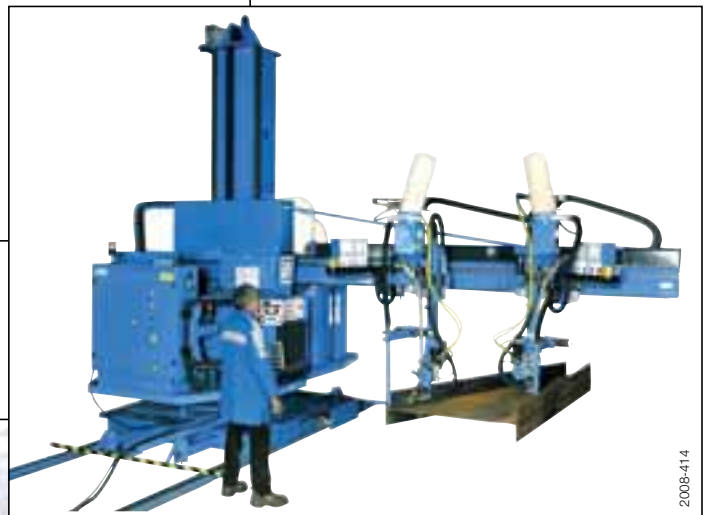

CLAMPING BENCH:

Clamping bench allows the positioning of H beam on a mechanical structure.

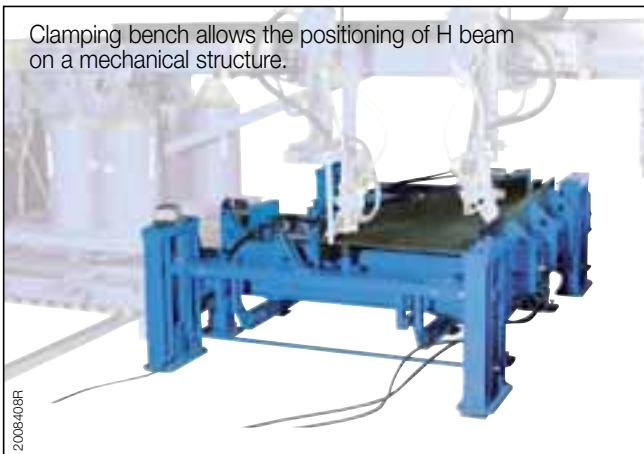

STANDARD DIMENSIONS FOR CLAMPING BENCH

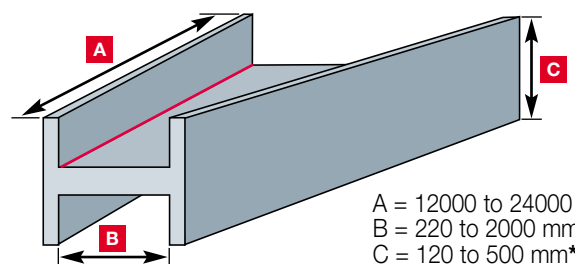

A = 12000 to 24000 mm*
B = 220 to 2000 mm*
C = 120 to 500 mm*

Web thickness: 4 to 20 mm
Flanges thickness: 10 to 30 mm

* Other dimensions consult us.

GYRMATIC

2000-050/52
2000-017



3100-002

2000-017

The GYRMATIC 350 & 500 are modular systems designed to adapt easily and quickly to all conditions for circular welding around a horizontal or vertical axis or in intermediate positions set using a manual tilt device.

They are designed for manual or automatic MIG / MAG or TIG welding of circular parts secured to the turntable or between tailstocks.

Example of GYRMATIC 350 assembly

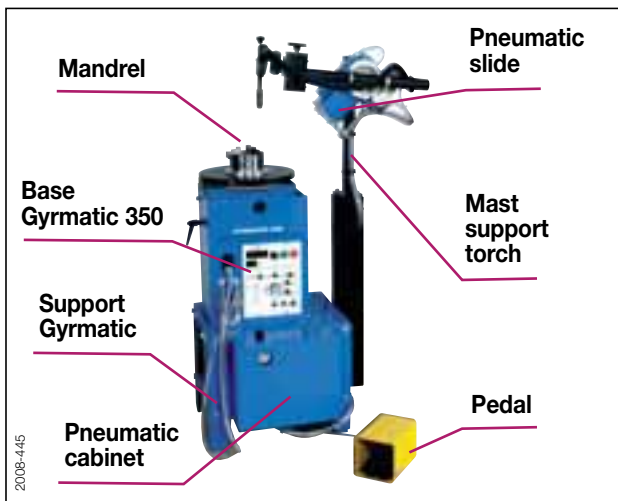

Example of GYRMATIC 500 assembly

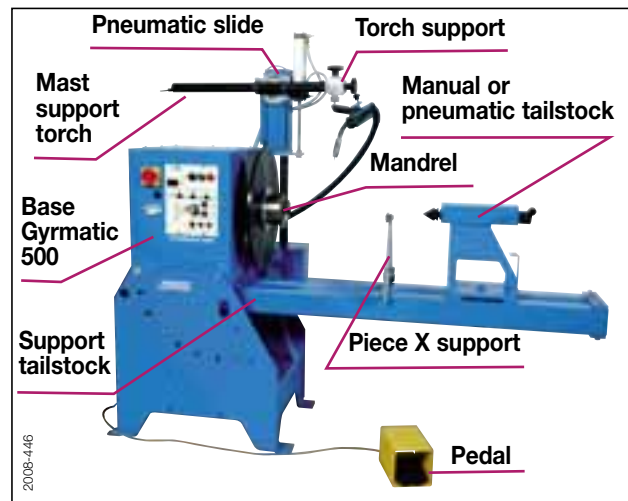

Not shown: pneumatic cabinet and electrical cabinet.

- 1 Automatic cycle start/stop.
- 2 Manual control to start up part rotation with direction selector.
- 3 Raise/lower torch (option).
- 4 Display of rotation speed (option).
- 5 Selection of part rotation direction in foot pedal control mode.
- 6 Selection of workpiece rotation direction in automatic mode.

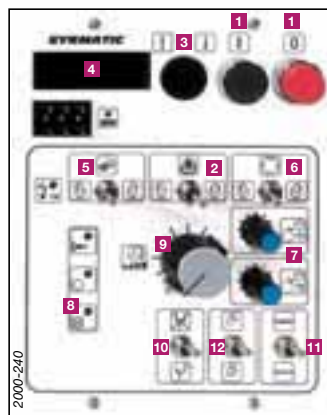

- 7 Time-delays controlling overlap area and stop time before reset.
- 8 LED display of current cycle status.
- 9 Adjustment of workpiece rotation speed by potentiometer to guarantee constant, regular movement.
- 10 Selection of automatic cycle mode: with or without welding.
- 11 Selection of welding mode: continuous or intermittent
- 12 Selection of one or two lathes.

Technical specifications:

Turntable	Base GYRMATIC 350		Base GYRMATIC 500		
	Cat. no.	W 000 315 895	W 000 315 276	W 000 315 265	W 000 315 269
Weld axis					
Rotation speed	0.9 to 18.5 tr/min	0.29 to 7.4 tr/min	0.25 to 4.5 tr/min	0.5 to 10 tr/min	
Number of earth clips	One 250 A clip - capacity can be increased to 500 A as option				
Back gas	option	option	option	option	
Intermittent welding	option	option	option	option	
Mechanical specifications					
Machined turntable diameter	Ø 350 mm	Ø 350 mm	Ø 490 mm	Ø 490 mm	
Max. rotation torque	1 m/daN	2 m/daN	5 m/daN	10 m/daN	
Max. workpiece diameter with tailstock	Ø 300 mm	Ø 300 mm	Ø 500 mm	Ø 500 mm	
Max. workpiece length with tailstock	300 mm	300 mm	800 mm	800 mm	
Possible tilt	Manual from 0° to 90° with 7 set positions at 15° intervals				
Dimensions / Power supply					
Dimensions (L x H x D)	430 x 508 x 408 mm	430 x 508 x 408 mm	600 x 1150 x 750 mm	600 x 1150 x 750 mm	
Power supply	230 V / 50-60 Hz	230 V / 50-60 Hz	230 V / 50-60 Hz	230 V / 50-60 Hz	
Unloaded weight without welding equipment	38 kg	38 kg	140 kg	140 kg	

ROTAMATIC: Single roller rotator



Easy-to use line of rotators covering a load carrying range from 2 tons up to 200 tons (Drive unit + Idler unit).

Medium-duty rotator: 2 T to 30 T

- ◇ Single powered (one drive roller) for small unbalance work piece.
- ◇ Double powered (two drive rollers) for work pieces having significant unbalance.
- ◇ Roller-to-roller center distance adjusting by screw (except for ST 2: by step).
- ◇ Remote pendant on all versions.
- ◇ Possible options:
 - kit auto
 - kit display
 - kit $\pm 1\%$ speed regulation
 - kit encoder 5000 pts
 - lorry and railway

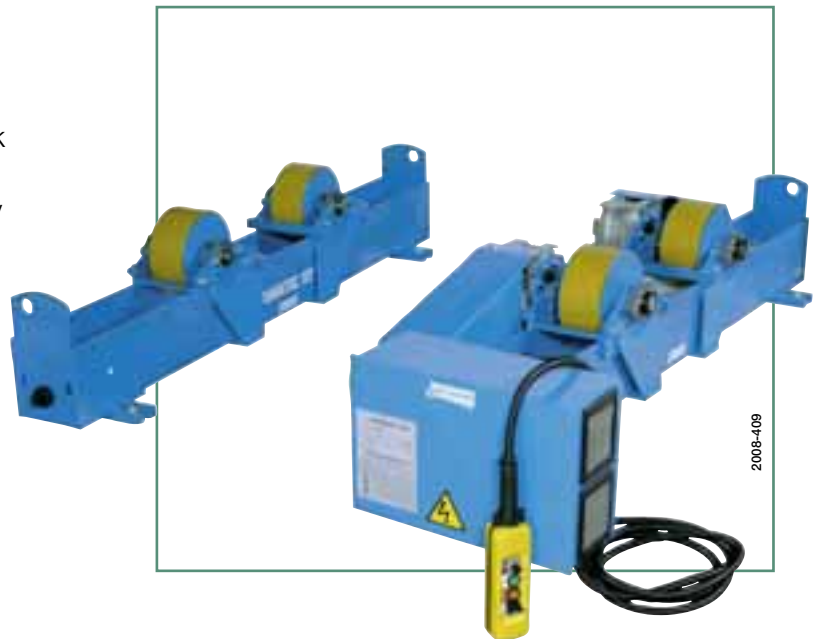

Technical specifications:

Designation		Cat. no.	Load capacity (1 drive + 1 idler) kg	Load capacity per section kg	Shell diameter mm	Peripheral speed cm/min	Wheel dimension OD x width	Wheel material
ST 2	MT	W 000 315 290	2000	1000	30 to 2500	12 to 120	Ø 150 x 50	Polyuretane
	M	W 000 315 289						
	W	W 000 315 288						
	F	W 000 315 291						Polyamide
ST 6	M	W 000 315 297	6000	3000	300 to 3500	12 to 120	Ø 250 x 75	Polyuretane
	W	W 000 315 296						
	F	W 000 315 298						
ST 15	M	W 000 315 304	15000	7500	300 to 4000	12 to 120	Ø 250 x 110	Polyuretane
	W	W 000 315 303						
	F	W 000 315 305						
ST 30	W	W 000 315 309	30000	15000	350 to 4500	12 to 120	Ø 350 x 150	Polyuretane
	F	W 000 315 310						

Keys:

M = Single motorization
W = Double motorization

F = Idler roll
MT = Single motorization with tube system



Heavy-duty rotator: 42 T to 200 T

- ⇒ Special frame conception with built-in roll supports reduces welding height from the ground.
- ⇒ Machined bed on the idler and drive roll for perfect alignment.
- ⇒ Remote pendant, kit auto and display in standard on all versions.
- ⇒ Possible options:
 - lorry and railway
 - screw adjusting or step adjusting

For a higher capacity rotators: consult us.

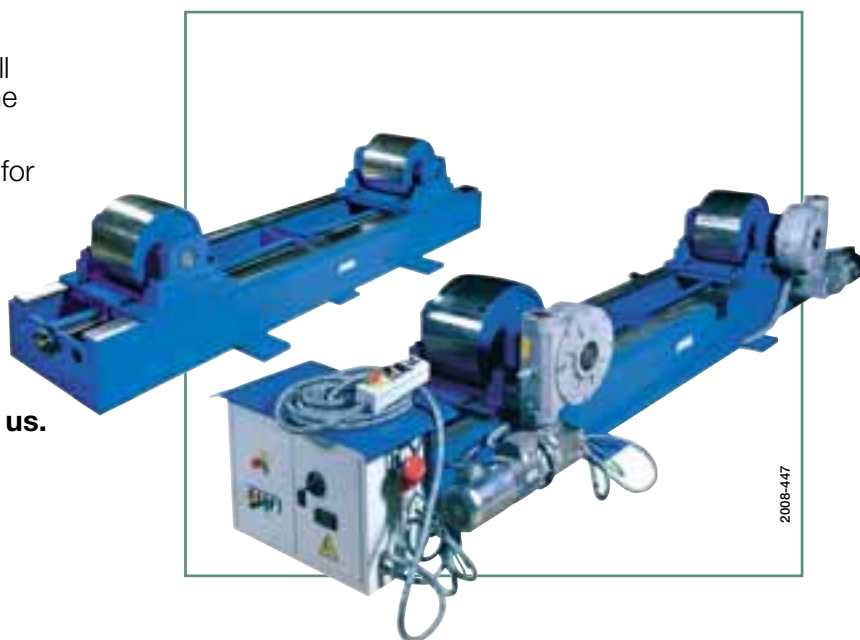

Technical specifications:

Designation	Load capacity (1 drive + 1 idler) kg	Load capacity per section kg	Shell diameter mm	Peripheral speed cm/min	Wheel dimension OD x width	Wheel material
LP42*	42000	21000	700 to 5000	10 to 100 or 9 to 180	Ø 400 x 200	Steel
					Ø 400 x 250	polyuretane
LP55*	55000	27500	700 to 5000	10 to 100 or 9 to 180	Ø 400 x 250	Steel
					Ø 400 x 300	polyuretane
LP70*	70000	35000	900 to 6000	10 to 100 or 8 to 160	Ø 460 x 250	Steel
					Ø 460 x 300	polyuretane
LP100*	100000	50000	900 to 6000	10 to 100 or 8 to 160	Ø 450 x 250	Steel
					Ø 460 x 300	polyuretane
LP160*	160000	80000	1200 to 6000	10 to 100 or 9 to 160	Ø 450 x 300	Steel
LP200*	200000	100000	1200 to 6000	10 to 100 or 10 to 160	Ø 500 x 300	Steel

* Available in version **W** (Double motorization) or **F** (Idler roll)

ROTAMATIC: Fit-up rotator



2570-003

The fit-up rotator allows to manipulate the vessels without any other exterior elements (crank...).

Up to 200 tons, with 1 set of single roller rotators (idler + motorized) and 2 fit-up rotators, the operators can easily adjust the vessels in order to make a good adjustment of the shells.

Fit-up rotator: 30 T to 200 T

- ⇨ In standard, the up and down movement is made by a manual hydraulic pump.
- ⇨ Possible options:
 - automatic hydraulic pump (hydraulic central)
 - lorry and railway

For a higher capacity rotators: consult us.

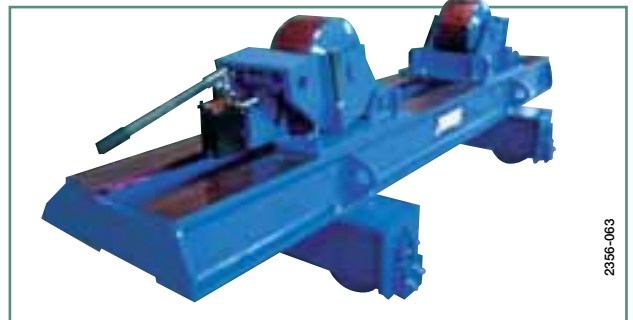

2356-003

Technical specifications:

Designation	Load capacity (2 fit up) kg	Lifting capacity per section kg	Shell diameter mm	Wheel dimension OD x width	Wheel material	Wheels adjustment
TR30	30000	15000	700 to 4500	Ø 300 x 160	Polyuretane	Screw
TR42	42000	21000	700 to 5000	Ø 350 x 250	Polyuretane	Screw
TR55	55000	27500	700 to 5000	Ø 350 x 250	Polyuretane	Screw
TR70	70000	35000	900 to 6000	Ø 400 x 300	Polyuretane	Screw
TR100	100000	50000	900 to 6000	Ø 400 x 250	Steel	Step
TR160	160000	80000	1200 to 6000	Ø 450 x 250	Steel	Step
TR200	200000	100000	1200 to 6000	Ø 450 x 300	Steel	Step

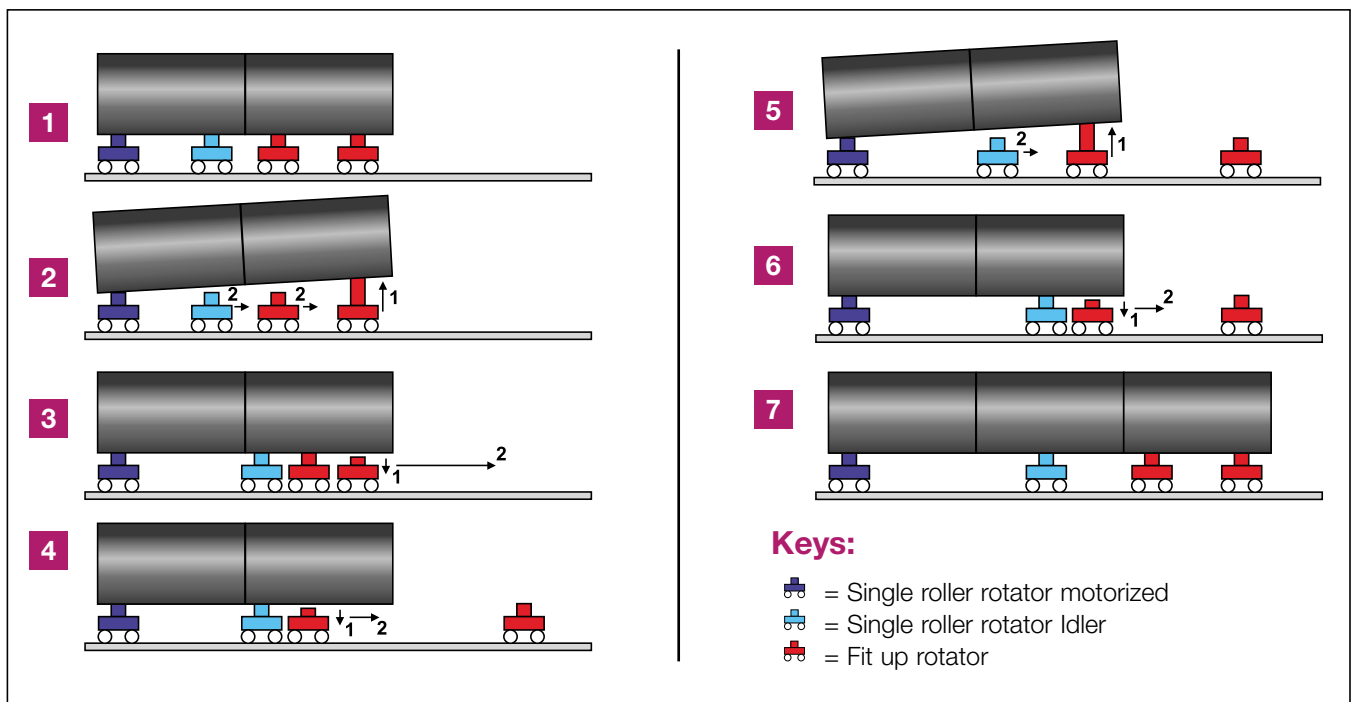

ROTAMATIC: Self-aligning rotator



The self-aligning rotator range, up to 250 tons (Drive unit + Idler unit), allows the easy positioning of pieces.

The rollers tilting allows to align the piece with the rotator without pre-adjusting of the rollers.

12 T to 250 T

⇒ In standard: Remote pendant, kit auto and display on all versions.

⇒ Possible options:

- lorry and railway

For a higher capacity rotators: consult us.

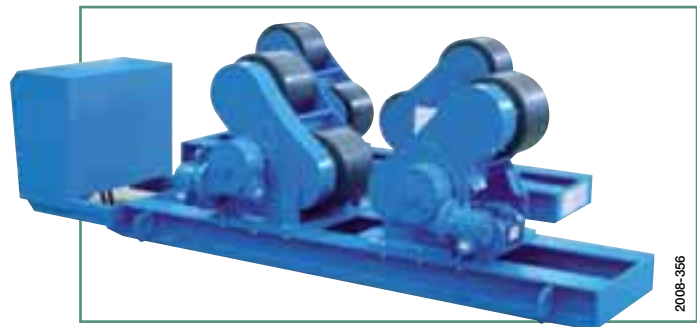

Technical specifications:

Designation	Load capacity (1 drive + 1 idler) kg	Load capacity per section kg	Mini Shell diameter for 1/2 load mm	Shell diameter for maximum load mm	Peripheral speed cm/min	Wheel dimension OD x width	Wheel material
LP12-2R*	12000	6000	500	1500 to 4000	10 to 100 or 10 to 200	Ø 300 x 220	Rubber
LP20-2R*	20000	10000	500	1500 to 4000	10 to 100 or 10 to 200	Ø 350 x 300	Rubber
LP30-2R*	30000	15000	500	1500 to 4500	10 to 100 or 8 to 160	Ø 400 x 300	Rubber
LP42-2R*	42000	21000	500	1500 to 5000	10 to 100 or 9 to 180	Ø 400 x 400	Rubber
LP55-2R*	55000	27500	800	1800 to 5000	10 to 100 or 9 to 180	Ø 500 x 230	Rubber
LP70-2R*	70000	35000	800	1800 to 6000	10 to 100 or 9 to 180	Ø 500 x 400	Rubber
LP100-2R*	100000	50000	600	1500 to 6000	10 to 100 or 8 to 160	Ø 420 x 300	Polyuretane
LP160-2R*	160000	80000	1000	1500 to 6000	10 to 100 or 8 to 160	Ø 460 x 300	Polyuretane
LP200-2R*	200000	100000	1000	1500 to 7000	10 to 100 or 7.5 to 150	Ø 500 x 300	Steel
						Ø 500 x 300	Polyuretane
LP250-2R*	250000	125000	1000	1500 to 7000	10 to 100 or 7.5 to 150	Ø 500 x 300	Steel
						Ø 550 x 400	Polyuretane

* Available in version **W** (Double motorization) or **F** (Idler roll)

ROTAMATIC options

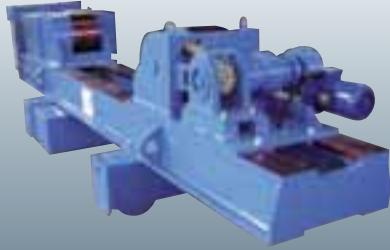

Options are available to make easy the manipulation of pieces with rotators.

Lorry

The lorry allows to move the rotators with or without the piece.

The idler lorry and the motorized lorry can be mounted on same line.

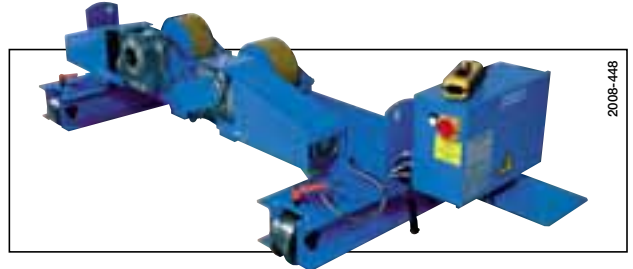

For Rotators

	Idler lorry	Motorized lorry	Translation speed m/min
ST 6 / ST 15 / ST 30	W 000 272 254	-	-
LP12-2R / LP20-2R / LP30-2R / TR30	LFC 30	-	-
LP42 / LP55 / LP42-2R / LP55-2R / TR42 / TR55	LFC 55	LMC 55	1,5
LP70 / LP100 / LP70-2R / LP100-2R / TR70 / TR100	LFC 100	LMC 100	1,4
LP160 / LP200 / LP160-2R / LP200-2R / TR160 / TR200	LFC 200	LMC 200	1,2
LP250-2R	LFC 250	LMC 250	1,2

Antidrift system

The manual antidrift device allows the piece to turn without twisting.

This system is fixed on the idler rotator.

For Rotators	Manual Antidrift Device
LP12-2R / LP20-2R / LP30-2R / TR30	MAD 30
LP42 / LP55 / LP42-2R / LP55-2R / TR42 / TR55	MAD 55
LP70 / LP100 / LP70-2R / LP100-2R / TR70 / TR100	MAD 100
LP160 / LP200 / LP160-2R / LP200-2R / TR160 / TR200	MAD 200
LP250-2R	MAD 250

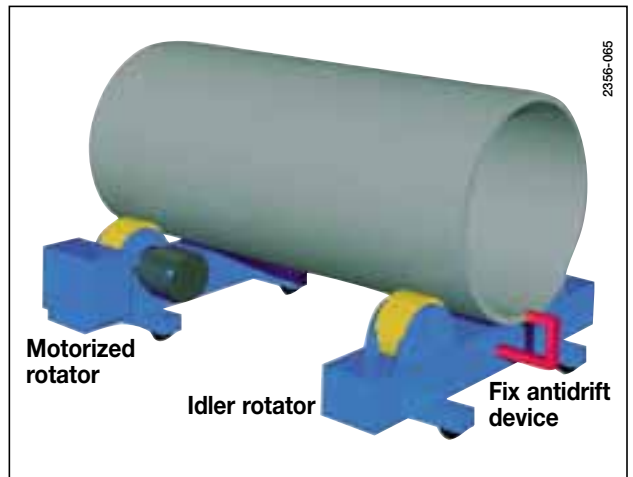

Special rotators

Possible to customize rotators

Here example:

Small rotators: 6 tons, 100 to 600 mm diameter



Positioners: POSIMATIC



Air Liquide Welding offers a range of positioners tables of varying capacities. These devices therefore provide significant improvements in productivity, operator ergonomics and quality standards, both for manual work and for medium series production.

2 types of positioners are available:

- conventional: from 100 kg to 30 T
- with lifting table: from 1500 kg to 10 T

For higher capacity or different rotation speed range, please consult us.

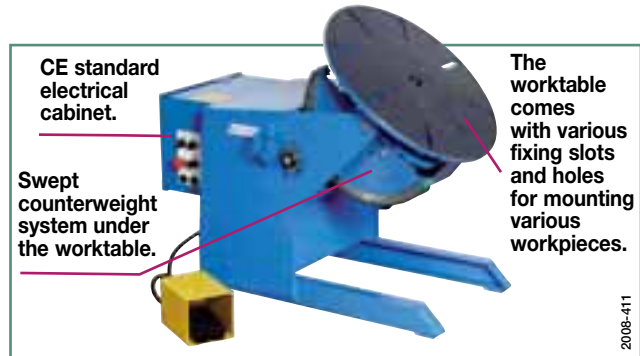

	Cat. no.	Load all positions kg	Tilt torque m.kg	Rotation torque m.kg	Rotation speed tr/min	Turntable height mm	Remote control or pedal	Pictures
P1E 1	W 000 315 254	100	25	2	0.2 to 5	385	Pedal	1 2008-316
P2E	W 000 315 256	200	40	4	0.25 to 5	500	Pedal	
3F	W 000 315 255	400	90	20	0.14 to 2.2	650	Pedal	
7F 2	W 000 315 257	650	175	75	0.076 to 1.53	896	RC	2 2008-320
16B 3	W 000 315 258	1600	400	150	0.074 to 1.48	975 to 1400	RC	
30B	W 000 315 259	3000	840	250	0.06 to 1.18	980 to 1380	RC	
TP4	Consult us	4000	1100	500	0.045 to 0.45	1110	RC	
TP6	Consult us	6000	2500	720	0.03 to 0.3	1150	RC	
TP8	Consult us	8000	3600	850	0.025 to 0.25	1000	RC	3 2008-412
TP10	Consult us	10000	6750	1450	0.022 to 0.22	1190	RC	
TP15 4	Consult us	15000	10300	2100	0.02 to 0.2	1275	RC	
TP20	Consult us	20000	14200	2900	0.018 to 0.18	1340	RC	
TP30	Consult us	30000	22500	4400	0.015 to 0.15	1450	RC	4 2008-398
TPE 1.5	Consult us	1500	375	160	0.06 to 0.6	970 to 1700	RC	
TPE 2.5	Consult us	2500	600	200	0.06 to 0.6	1030 to 1850	RC	
TPE 4	Consult us	4000	1100	500	0.045 to 0.45	1060 to 2010	RC	
TPE 6	Consult us	6000	2500	720	0.035 to 0.35	1125 to 2125	RC	
TPE 8	Consult us	8000	3600	850	0.025 to 0.25	1125 to 2125	RC	2008-449
TPE 10	Consult us	10000	6750	1450	0.022 to 0.22	1150 to 2350	RC	

Turn-tables: TURNMATIC



Air Liquide Welding propose a range of turn-table up to 30 tons. A backing gas device can complete a welding solution with column and boom and plasma welding.

Turntable 5 T to 30 T

A circular welding can be done by the movement of the turn table without moving the torch. In the standard range, a turn table can make the rotation of shells up to 30 tons and up to 4500 mm diameter.
For other sizes, capacities or rotation speed range: consult us.

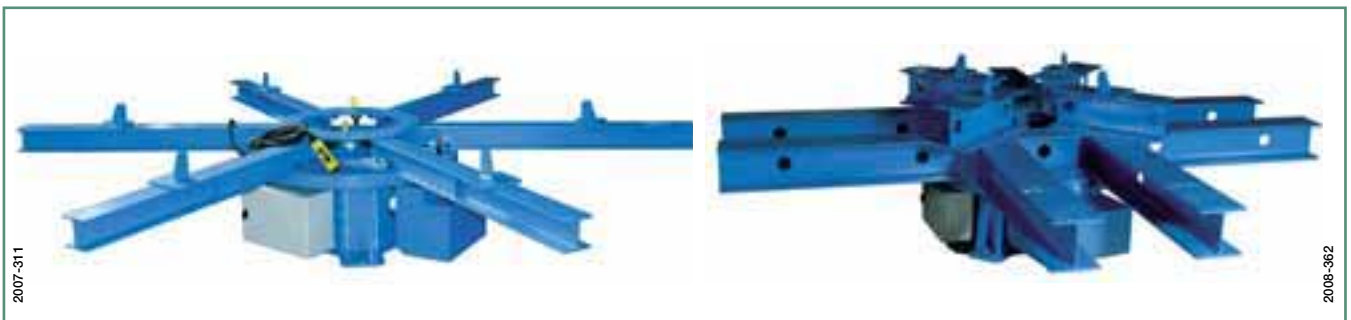

Designation	Load capacity kg	Mini Shell diameter mm	Maxi Shell diameter mm	Rotation speed tr/min
Turnmatic 5 T	5000	1200	4500	0,004 to 0,204
Turnmatic 10 T	10000	1000	4500	0,004 to 0,204
Turnmatic 20 T	20000	1000	4500	0,004 to 0,204
Turnmatic 30 T	30000	1000	4500	0,004 to 0,204

Backing gas device:

The backing gas device mounted on turn table, complete the turn-key solution of plasma welding column and boom.

A man hole in the turn table allows the operator to adjust the backing gas device inside the shell.

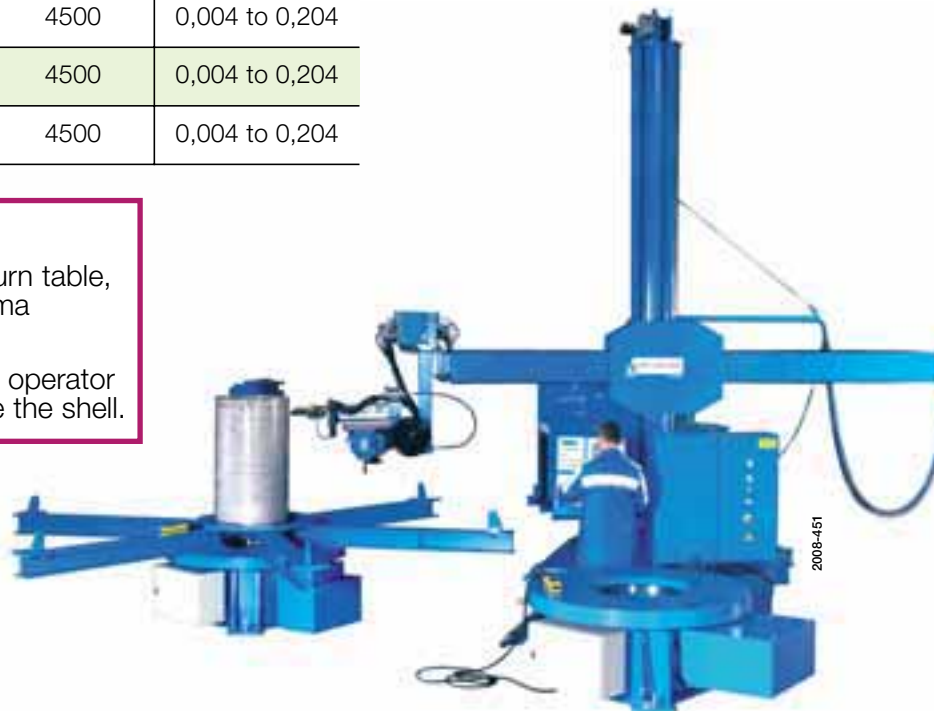
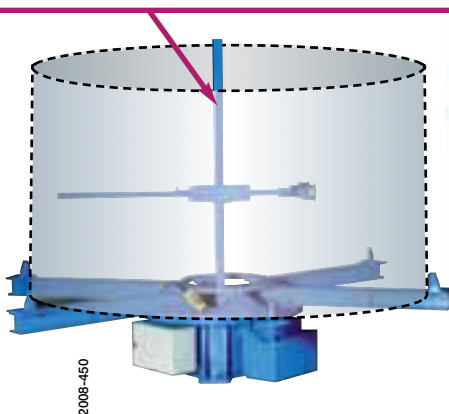

For other sizes, capacities or rotation speed range: consult us.

Headstock: HEADMATIC

A complete range of headstock allows the rotation piece in horizontal position.

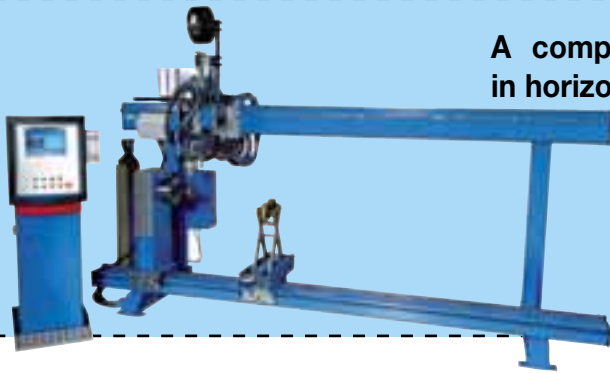

Headstock:

The headstock range allows to make rotations of piece up to 3 tons.

2 types of headstock:

- MINITOP, TOP and SUPERTOP to be integrated on a mechanization
- H range for manual manipulation or integrated on machine.

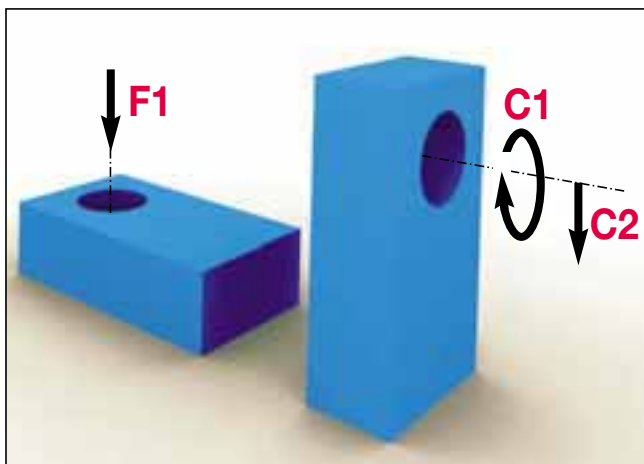

Designation	Motorized Cat. no.	Idler Cat. no.	Flat Load capacity (F1) kg	Rotation torque (C1) m.kg	Tilting torque (C2) m.kg	Rotation speed tr/min
MINITOP 26.8 tr	W 000 315 429	W 000 315 426	50	3.6	14	2.7 to 26.8
MINITOP 8.25 tr	W 000 315 427		50	9.4	14	0.82 to 8.25
MINITOP 3.75 tr	W 000 315 425		50	16	14	0.37 to 3.75
TOP	W 000 315 371	W 000 315 367	300	15	90	0.05 to 4.5
SUPERTOP 1	W 000 315 397	W 000 315 402	1000	45	300	0.05 to 5
H 0.7 (700 kg)	HM 0.7	HF 0.7	-	70	210	0.1 to 2
H 1.5 (1500 kg) 2	HM 1.5	HF 1.5	-	150	450	0.07 to 1.4
H 3 (3000 kg)	HM 3	HF 3	-	300	900	0.06 to 1.2

Mechanization

Air Liquide welding proposes to design machines with modular elements in order to build the machine around to piece to be welded or cut. The mechanization allows to save time for your project of machine.

Machine design

Machine realization

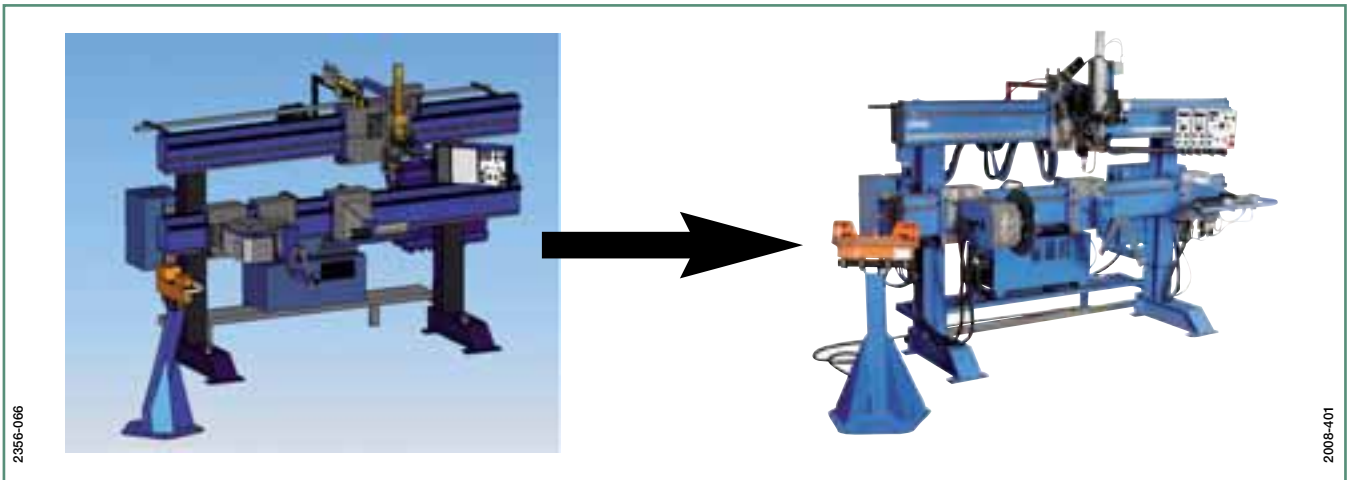

A large choice of mechanization parts

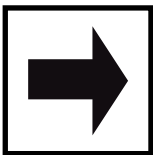

Beam, carriage, manual or motorized slides...

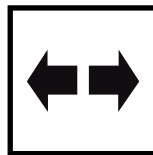

Oscillation mechanism...

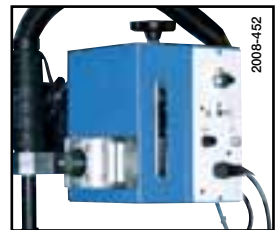

Headstock, tailstock, rotation block, mandrel...

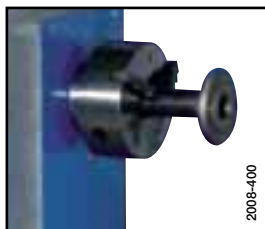

X rotators, support blocks, command box supports...



Sensortrack probe, laserprobe, mechanical tracking...

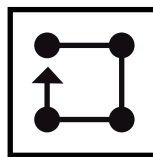
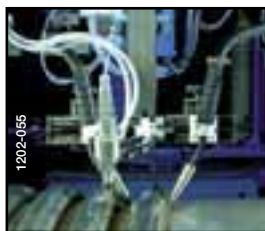

Mecacycle, electrical cabinet...



Headstock mechanization
on CTP2 beam



2008-453

SAW platform
for school training

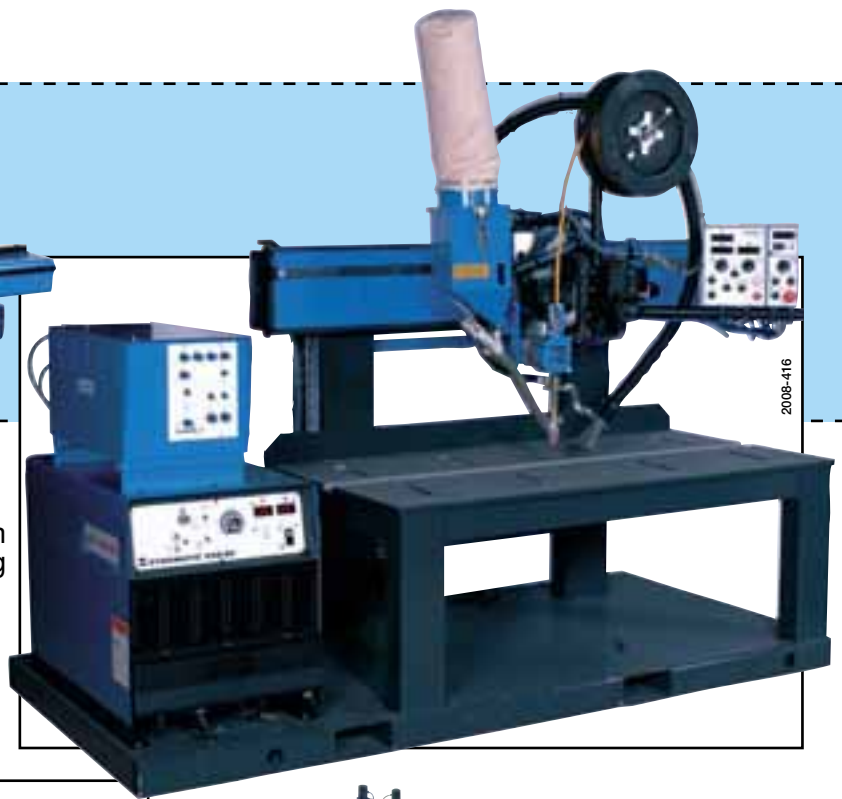

2008-416

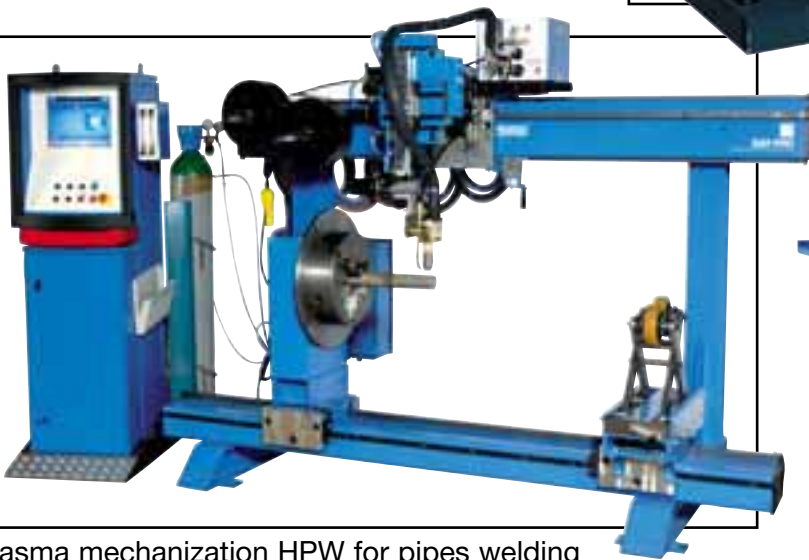

2008-417

Plasma mechanization HPW for pipes welding

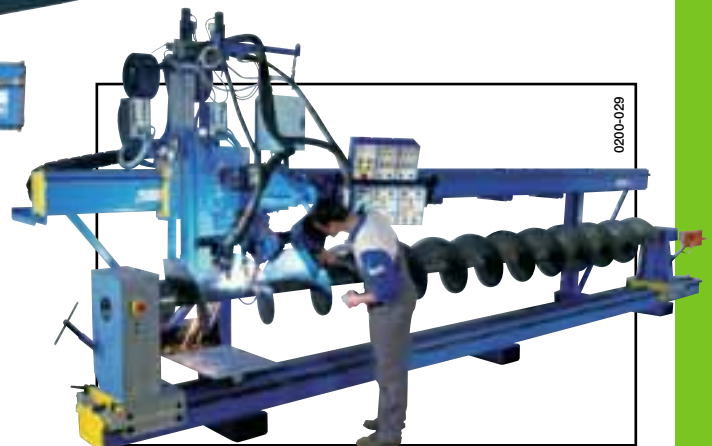

0200-029

Double MIG mechanization
for unless screw welding

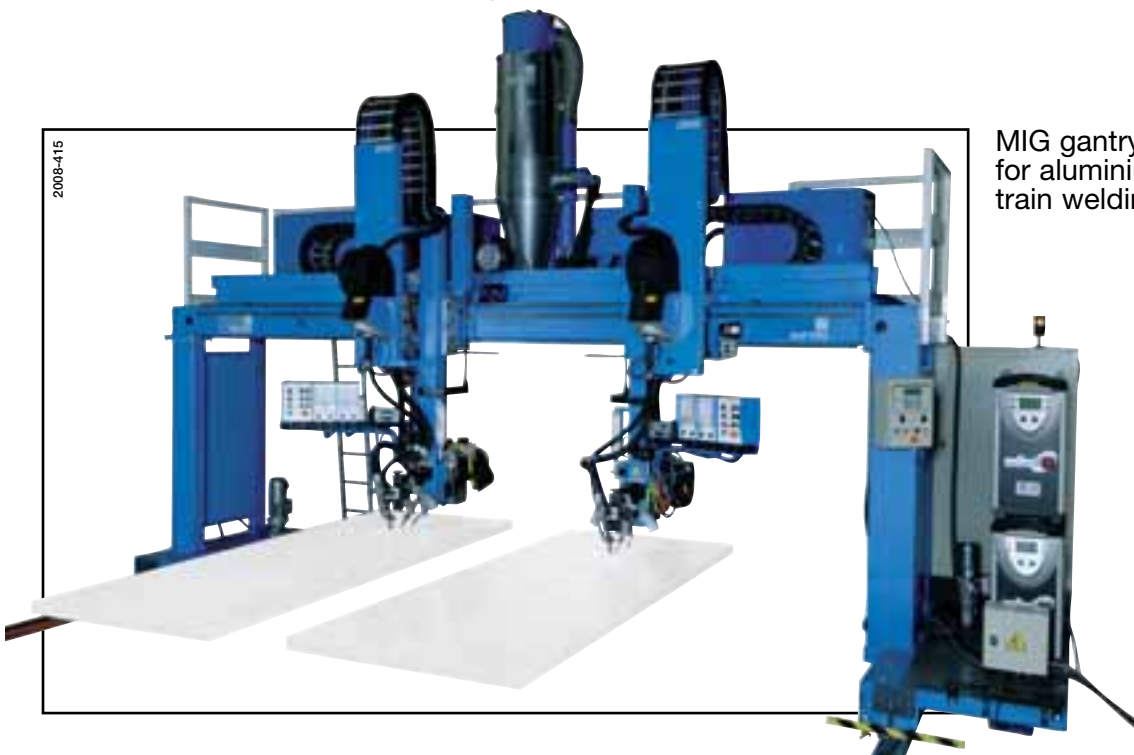

2008-415

MIG gantry
for aluminium train welding